



---

**810103**  
**IP01 SERIES**  
**1:1 RATIO TRANSFER PUMP**  
Operations Manual



---

**IPM, INC.**

Manufactured by International Pump Manufacturing, Inc

# IP01 series

## 1:1 RATIO TRANSFER PUMP

### OPERATING MANUAL and PARTS IDENTIFICATION DRAWINGS

This manual contains IMPORTANT WARNINGS and INSTRUCTIONS. Read and retain for future reference.

INTERNATIONAL PUMP MANUFACTURING, INC.  
3107 142nd Avenue E Suite 106,  
Sumner, WA 98390  
U.S.A.  
TEL: (253) 863 2222  
FAX: (253) 863 2223  
Website: [www.ipmpumps.com](http://www.ipmpumps.com)

**For Technical Service Call Your Local Distributor**

Copyright 2018 by: International Pump Mfg, Inc.

---

---

**WARNING:** The equipment described herein must only be operated or serviced by properly trained individuals thoroughly familiar with the operating instructions, mechanics and limitations of the equipment.

---

Notice: All statements, information and data given herein are believed to be accurate and reliable but are presented without guarantee, warranty or responsibility of any kind expressed or implied. Statements or suggestions concerning possible use of IPM equipment are made without representation or warranty that any such use is free of patent infringement and are not recommendations to infringe any patent. The user should not assume that all safety measures are indicated or that other measures may not be required.

# TABLE OF CONTENTS

1.0 SAFETY WARNINGS .....	4
2.0 INSTALLATION .....	8
2.1 Installation procedures.....	9
3.0 OPERATION.....	10
3.1 Start up and adjustment of transfer pump.....	10
3.2 Shut down procedure.....	10
3.3 Daily maintenance check.....	11
3.4 Disassembly procedure .....	11
3.5 Assembly procedure .....	15
4.0 PARTS IDENTIFICATION .....	16
5.0 REPAIR KITS .....	20
6.0 TROUBLE SHOOTING.....	21
7.0 TECHNICAL SPECIFICATIONS.....	22
8.0 WARRANTY AND DISCLAIMER.....	24

## **1.0 SAFETY WARNINGS**

Please read and observe all warnings contained in this operation manual before making any attempt to operate the equipment.

### **Warning**

To reduce the risk of static sparking or splashing fluid in the eyes or on the skin, follow the [Procedure for Pressure Relief](#) (page 5) before flushing.

For your safety, read the [Hazard from Fire or Explosion](#) (page 6) before flushing and follow all the listed recommendations.

### **Misuse of Equipment**

Misuse of equipment can cause serious bodily injury. Use the equipment only for its intended purpose and do not attempt to modify it in any way. Care should be taken to prevent over pressurization of the pump, hose lines and accessories connected to it. Use only IPM designated parts for re-building or repairing this equipment. Use the pump only with compatible fluids. Improper use of this equipment could result in fluid being sprayed on the skin or in the eyes of user, serious bodily injury, property damage, fire or explosion.

Daily maintenance inspection should be made on pumps and equipment and all worn or damaged parts should be re-placed immediately. Do not use pumps, components or hose lines as leverage to move equipment to avoid damage and injury.

Do not alter this equipment as doing so could cause it to function incorrectly and/or cause serious injury. Altering this equipment in any way will also void all warranty guarantees from the manufacturer.

### **Material & Fluid Compatibility**

Always ensure the chemical compatibility of the fluids and solvents used in the fluid section of these pumps, hoses other components. Check the chemical manufacturer's data sheets and specification charts before using fluids or solvents in this pump to ensure compatibility with pumps, inner hose lining and outer hose covering.

### **Pressurized Hoses**

Because the hoses are pressurized, they can present a danger should the fluid escape due to damage, worn parts or general miss-use. Escaping fluid can splash or spray operator, causing serious bodily injury and/or damage to equipment and property. Ensure that the hoses do not leak or rupture due to wear, misuse or damage.

Before each use, ensure that the fluid couplings are tight, and all clips/pins/plugs are secured. Inspect the entire length of hose for wear, cuts, abrasions, bulging cover and/or loose connections. These conditions may cause the hose to fail and result in splashing or spraying of chemicals on the skin or in the eyes of operator and cause serious injury and/or property damage.

## **Pressure Specification**

The maximum working pressure of this equipment for fluids and air is 180 psi (12.4bar). Ensure all equipment and accessories used with this pump are rated to withstand the maximum working pressure of this pump. Never exceed the maximum working pressure of the pump, hose lines or any other components attached to the pump itself.

## **Procedure for Pressure Relief**

In order to avoid the risk of serious injury to operators from splashing/spraying chemicals, the following safety procedures should be used. This procedure should be used when shutting down the pump, performing general maintenance, repairing a pump or other components of the system, replacing components or when pumping operation is ceased.

1. Close the air valve to the pump.
2. Use the air bleed down valve (see INSTALLATION, page 8) to relieve the air pressure in the system.
3. Relieve the fluid pressure by holding a grounded metal pail in contact with the metal part of the fluid dispense valve and slowly opening the valve.
4. With a container ready to catch the fluid, open the drain valve (see INSTALLATION, page 8).
5. It is a good practice to leave the drain valve open until it is time to dispense fluid again.

If you are unsure that the fluid pressure has been relieved due to a blockage in a component or a hose, carefully relieve the pressure by carefully loosening the hose end coupling to allow the fluid pressure to escape slowly. After the pressure has been relieved, the fitting can then be removed, and any blockages removed.

## **Flush the Pump Before Initiating Operation**

1. The pump is tested with lightweight DOP oil, which is left in to protect the pump parts. If the fluid you are pumping may become contaminated by oil, flush oil from pump with a compatible solvent before use. Follow the flushing instructions below.
2. When pumping fluids that set up or solidify, flush the system with a compatible solvent as often as necessary to remove build-up of solidified chemicals in the pump or hoses.
3. If the pump is being used to supply a circulating system, allow the solvent to circulate through the entire system for at least 30 minutes every 48 hours or more often if necessary, to prevent settling and solidification of chemicals.
4. Always fill the wet-cup 1/2 full of throat seal liquid (TSL) or compatible solvent to keep the fluid from drying on the displacement rod and damaging pump throat packing.
5. Lubricate the throat packing frequently, when you are pumping a non-lubricating fluid or are shutting down for more than one day.

## **Shut Down & Care of Pump**

For Overnight shut down, follow the [Procedure for Pressure Relief](#) (page 5). Always stop the pump at bottom of the stroke to prevent the fluid from drying on the exposed displacement rod and damaging the throat packing.

## **Hazards from Fire or Explosion**

Hazards exist where sparks can ignite vapors or fumes from combustible chemicals or other hazardous conditions exist such as explosive dust, etc. These sparks can be created from plugging in or unplugging an electrical supply cord or from the static electricity generated by the flow of fluid through the pump and hose.

Every part of the equipment must be properly grounded to prevent static electricity from generating a spark and causing the pump or system to become hazardous. These sparks can cause a fire, explosion, property and equipment damage and serious bodily injury. Ensure that the pump and all components and accessories are properly grounded and that electrical supply cords are not plugged in when these hazards exist.

Should any evidence of static electricity (sparks or small shocks while in contact with the equipment) exist, discontinue pump operation immediately. Investigate the source of the static electricity and correct the grounding problem. Do not use the system until the grounding problem is repaired.

## **Grounding the Pump**

Always use the following procedures for grounding the pump. Loosen the lock screw to allow insertion of one end of a minimum sized 12-gauge wire into the bore hole of the grounding lug. Insert 12-gauge wire and tighten the lock screw securely. The other end of the ground wire must be secured to a true earth ground.

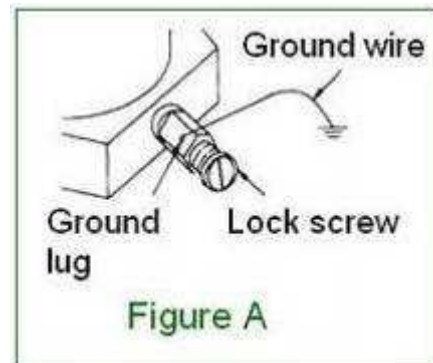

## **Grounding Procedures**

Grounding of the pump and all the other dispensing equipment is necessary to minimize the possibility of sparks due to static electricity. Grounding must be in compliance with, local electrical codes. Check with local authorities for requirements in your area and with the type of equipment being used. Ensure that all the following equipment is grounded:

1. Air compressor: Follow the grounding procedures as recommended by the compressor manufacturer.
2. Air hoses: Always use grounded air hoses.
3. Fluid container used to supply the system: Grounding must be done according to local electrical codes.
4. Pump: Follow the procedures referred to in Figure A (page 6).
5. Fluid Hoses: Always use grounded fluid hoses.

- |    |   |  |
|----|---|--|
| 6. | Dispensing Valve:   | The valve must be metal to conduct through the fluid hose to the pump which must be properly grounded.                     |
| 7. | Dispensing Point:   | Grounding must be done according to local electrical codes.  |
| 8. | Solvent Containers<br>codes. use only metal:                      | Grounding must be done according to local electrical conductive pails that are properly grounded.                          |
| 9. | Grounding while<br>dispensing, cleaning<br>or relieving pressure: | Maintain conductivity by firmly securing the metal part of the dispensing valve to the side of a grounded metal container. |

### **Hose Grounding**

It is very important that the hoses used for both air and fluid dispensing be a grounding type and that ground continuity is always maintained during operation. Regular checks of the hose ground resistance (with a resistance meter using a suitable range) and a comparison to the manufacturer's specifications will ensure that the ground is within specifications. If it is not within specified limits it should be replaced immediately.

### **Lubrication**

Transfer pump should be lubricated daily. Drain moisture from the air regulator. To manually lubricate the motor, disconnect the air lines at the motor and place approximately 10 of oil in the **air inlet**. Reconnect the air line and turn on the air to blow oil into the motor. Also keep the wet-cup filled with Throat Seal Liquid (TSL) or compatible solvent. This will reduce maintenance and prolong the packing life. Adjust the packing nut weekly so it is just tight enough to prevent leakage but do not over-tighten as this will restrict pump operation. Always follow the [Procedure for Pressure Relief](#) (page 5) before adjusting the packing nut.

### **Solvent Cleaning**

While cleaning the system with solvent, secure the metal part of the dispensing valve in contact with a grounded metal pail to minimize the possibility of splashing/spraying of chemicals on the skin, in the eyes and around static sparks. Use low fluid pressure for additional safety.

### **Hazards from Moving Parts**

Use the [Procedure for Pressure Relief](#) (page 5) to prevent the pump from starting unintentionally or unexpectedly. Be aware of moving parts that present a pinching hazard to fingers or other body parts. Always stay clear of these moving parts when starting or operating the pump.

### **Safety Standards**

Safety standards have been established by the United States Government under the Occupational Safety and Health Act. These standards should be consulted as they apply to the hazards and type of equipment being used.

## 2.0 INSTALLATION

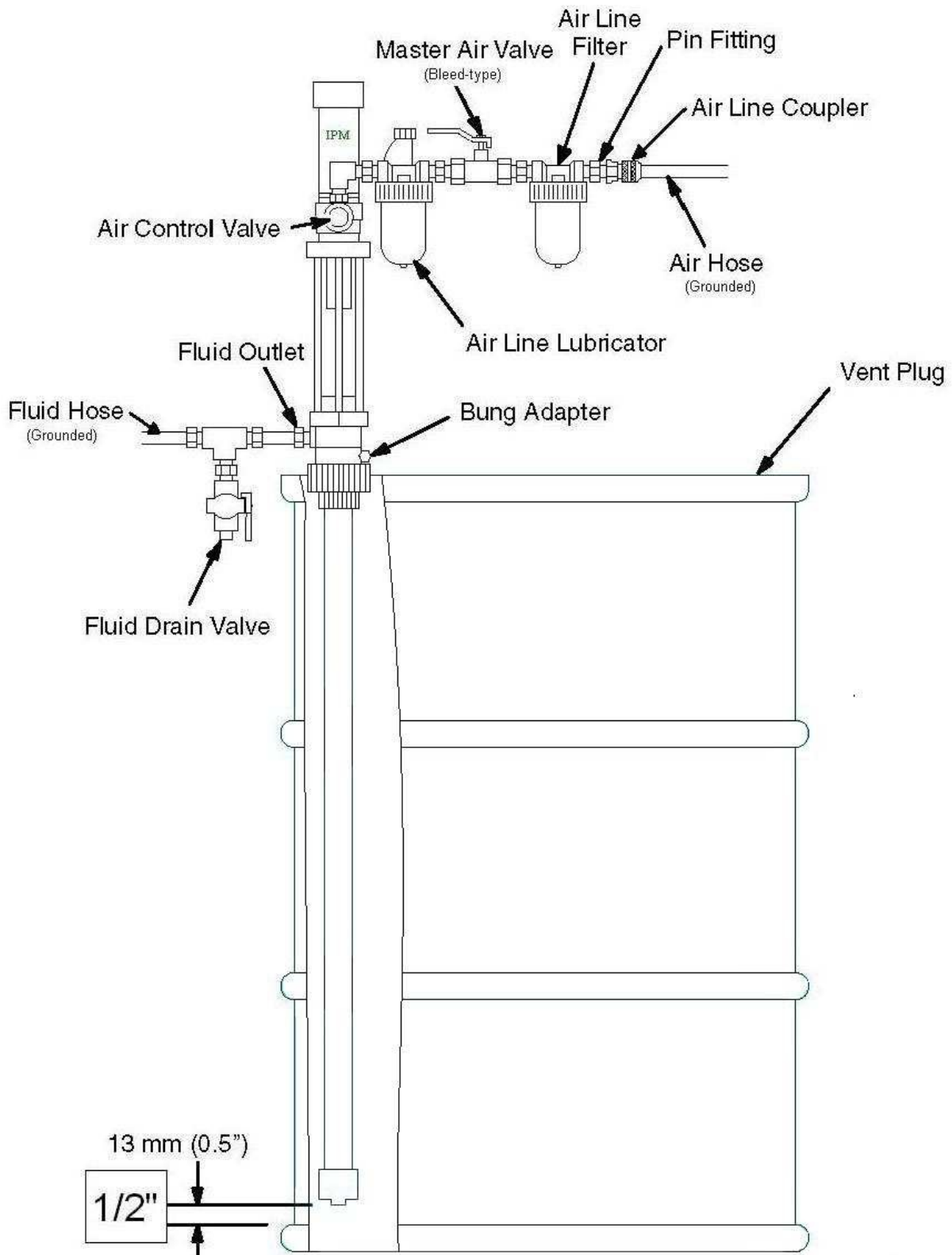

Figure B depicts only a typical installation providing a guide for your reference, but many other installation methods can be used based on your specific application. Some parts shown are not included but are sold separately. Feel free to call your **Local Distributor** for assistance.



## 2.1 Installation procedures

Install the necessary accessories in sequence using **Figure B** (page 8) as a guide. An air control valve (IPM part # 501804) for controlling air flow is required. To minimize the risk of serious injury such as splashing/spraying chemicals on the skin, in the eyes or injury from moving parts, install the following accessories in your system.

### 1. Bleed-off master air valve

This valve will relieve the air trapped in the system after pump operation is ceased. Air that is trapped between this valve and the pump can cause the pump to reciprocate un-intentionally or un-expectantly and may cause injury to the operator.

### 2. Fluid Drain Valve

The fluid drain valve is installed to relieve fluid pressure in the pump, hose or at the dispensing valve when pump operation is ceased. The relief of pressure by the dispensing valve, which at times is inadequate if there is a clog or other restriction in the hose or dispensing valve can be achieved by using this fluid drain valve. Always use a metal valve for grounding purposes.

## **Lubrication**

Connect an air lubricator to help achieve maximum pump longevity. The in-line lubricator provides proper lubrication to the air motor during operation. Next, install a bleed-off master air valve on the system. This valve is required on your system to relieve trapped air as explained above.

Air filters help to remove dirt and foreign particles from the supply air. Water moisture will also be trapped within this filter. Be sure to release the trapped water daily as a good maintenance practice. Connect a grounded air supply hose for main air supply.

For the fluid section, connect one fluid drain valve directly after the outlet of the pump. Be sure to connect it pointing downwards for safety. Connect a grounded fluid hose to the fluid outlet 3/4" NPT (female).

**Ensure that installation is fully completed before proceeding with startup operations.**

**Ensure grounding of the pump and accessories is completed before beginning pump operation. Observe all OSHA and other safety regulations.**

## 3.0 OPERATION

### 3.1 Start up and adjustment of transfer pump

1. Ensure that the air control valve is closed then open the bleed-type master air valve. Connect the quick disconnect coupler to the male fitting.
2. For safety, open the dispensing valve slowly, then drain fluid into a grounded metal container. Ensure metal-to-metal contact is always maintained between the container and the valve.
3. Adjust the air control valve slowly for just enough pressure to start running the pump. This is to prime all air within the system. After all the air has been expelled from the lines, close the dispensing valve. During the priming of the pump, the pump operates when the dispensing valve is opened and stops when the valve is closed.
4. Turn the air regulator slowly until sufficient flow from the dispensing valve is achieved. Remember to always run the pump at the lowest possible speed necessary to achieve what is desired. Never exceed the maximum working pressure of any component in the system.
5. The pump should not be left to run dry of the fluid being worked upon. When running empty, the operating speed will rise rapidly, increasing the chance of damage to the pump and/or components. During operation should the pump be found to run too fast, stop it immediately and ensure the fluid supply is not too low or the drum is empty. If air has gone into the system, repeat the priming procedure. Ensure that all air has been expelled from the lines before beginning operation again. Flush the pump or leave it filled with a compatible solvent when not in use.
6. Always follow the Pressure Relief Procedure should the pump be put away for any period or during system shut off at the end of the day.

### 3.2 Shut down procedure

1. Relieve the air pressure with the air regulator.
2. Open the air needle valve.
3. Bleed off residual pressure in the system with the bleed-off master air valve.
4. Open the drain valve to relieve fluid pressure in the system. Use a container to collect the fluid drained off. **Be especially careful as the fluid may still be under pressure.** Hold the metal fluid drain valve against the side of the grounded container while relieving the pressure.

**Note: For long periods of shutdown, flush the pump thoroughly with an appropriate cleaning fluid to prevent solidified chemical build-up.**

### 3.3 Daily maintenance check

1. Ensure sufficient lubricant in the air lubricator.
2. Keep the packing cup 1/2 filled with a suitable fluid to ensure the piston rod remains clean and lubrication is supplied to the packing.
3. Drain any moisture trapped in the air pressure cylinder.

**Note: Clean and flush the pump thoroughly with appropriate cleaning fluid to maintain the maximum service life of the equipment.**

### 3.4 Disassembly procedure

1. All inlet/outlet hoses should be removed, and the pump moved to a suitable work area.
2. Clamp on the outlet housing with the outlet hole against one of the jaws of the vice. Alternatively, a pipe clamp may be utilized instead of a vice. When clamping the housing, it becomes possible to remove either the air cylinder or the lower tube and/or foot valve.



3. Remove the foot valve, while holding the air cylinder with a strap wrench as shown.

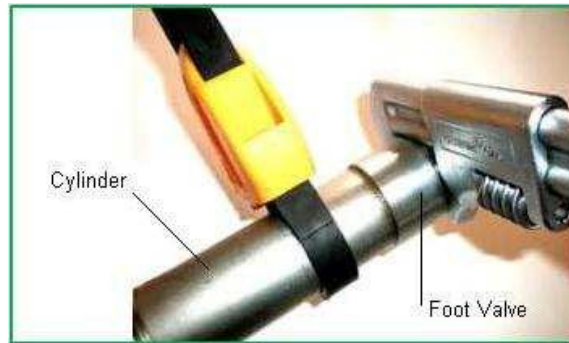

4. Use snap ring pliers to remove snap ring and E-clip. Remove check ball and examine foot valve for debris and/or damage. Replace as necessary. Replace Teflon O-ring and re-assembly foot valve with ball, snap ring and E-clip.

**A NOTE ON FOOT VALVES:** All foot valves have been converted to a higher flow capacity. This is a design element to reduce out-gassing and suction pressure within the pump. While the foot valves are readily interchangeable with the older style the internal components are not, so take care when ordering replacement parts.



5. With a strap wrench close to outlet housing, unscrew the air cylinder taking care NOT to bend the piston rod in the process. Examine air cylinder for damage to the interior cylinder wall by looking through the cylinder at an acute angle to a light source.

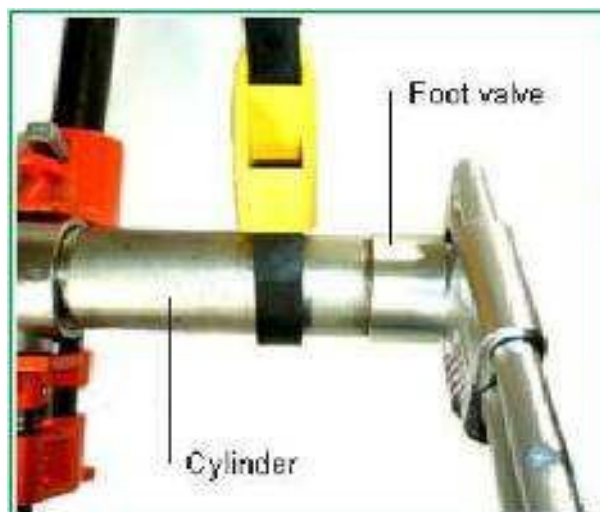

- At this point you can remove either the connecting rod from the displacement rod or the internal check valve from the connecting rod. Typically, you will be taking apart the internal check valve assembly to inspect and clean.

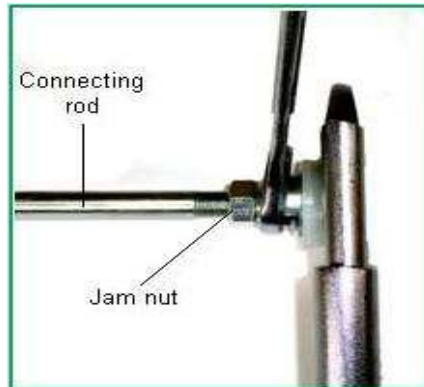

- Please note that you must loosen the hex nuts and re-tighten upon assembly.
- Carefully clamp piston valve housing in vice and unscrew piston pump. Remove the piston valve housing for buildup, debris or damage.
- Re-assemble the piston pump to the piston valve housing with the piston valve, washer and piston cup in place. Shown in the picture below are the components for the upper check valve.



- Re-assemble the hex nut onto the connecting rod. Install the piston valve housing assembly onto the connecting rod. Adjust the piston valve housing so that the tolerance between the connecting rod and the piston valve is between 0.060" and 0.080" using a feeler gauge for accuracy.

***This gap is extremely important because too much gap will not allow the fluid to flow correctly; too little or no gap will restrict the flow.***

- From the fluid section, remove the three lock nuts from the three tie rods. Slide complete air piston assembly out through the outlet housing. Complete air motor assembly part NO. is #700014 is shown in "4.0 Parts Identification for all pumps."

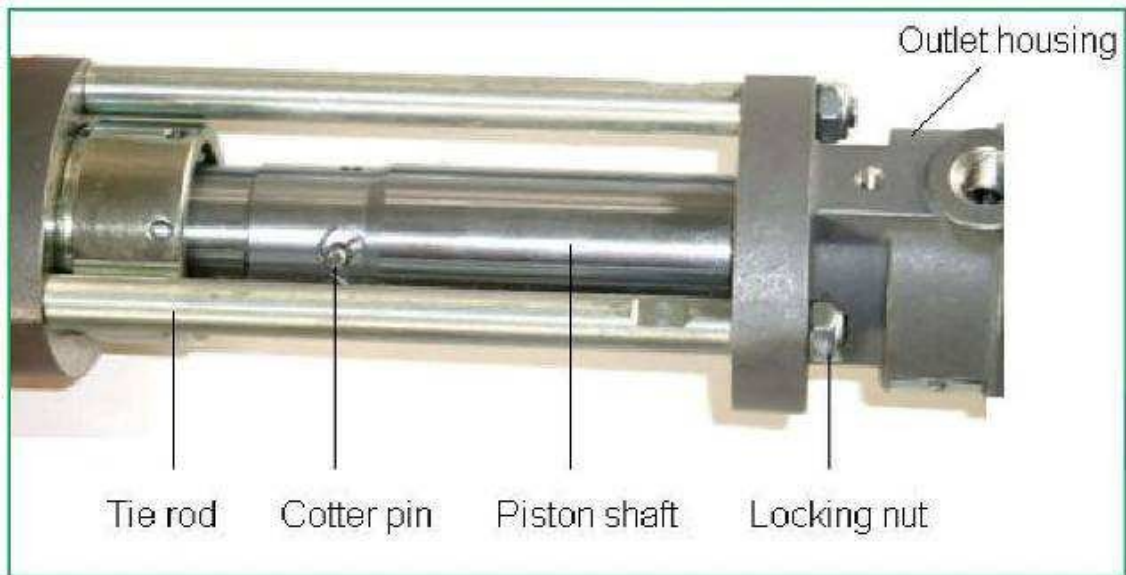

12. From the air motor section, remove the cotter pin then remove the flat head pin. Unscrew the displacement rod from the piston shaft, as shown in diagram above.
13. From the air section, remove the packing nut from the outlet housing and remove female gland, male gland and "V" block packing from the outlet housing. Examine all packing's for damage and replace if necessary. Examine the displacement rod for damage along its length and on both ends. Replace if necessary. Lubricate then re-assemble the packing parts (female gland, male gland and "V" block packing) onto the outlet housing. Tighten up the packing nut taking care not to over-tighten it to ensure no damage occurs to the packings.

14. Clamp the air motor assembly in a vice by the air motor base. Using a strap wrench near the base as shown, remove the air cylinder. Examine the conical spring in the air motor cap to ensure that it is not damaged or loose. Slide the air motor assembly with the piston shaft out through the air motor base. Examine the V- block packing for damage and replace if necessary. Examine the square cut gaskets in the air motor cap, top and bottom and replace if needed. This gasket seals the cylinder cap to the air cylinder. Look at air section illustration for a parts reference number.



15. From fluid section, unscrew displacement rod from the piston shaft. Examine for debris build-up or damage. Re-assemble the muffler with the point of the cone facing up inside the piston shaft. Screw the displacement rod into the piston shaft.
16. From air section, remove the air motor assembly from the piston shaft. Remove the three socket head cap screws. Examine the three small O-rings and one large O-ring and replace if necessary.

### 3.5 Assembly procedure

1. Align air motor assembly with parts seen in the component list picture below. The air exhaust valve plate and the screws require the use of threadlocker to ensure they do not vibrate loose during pump operation. Tighten the screws to a tolerance of 10-14 inch pounds.

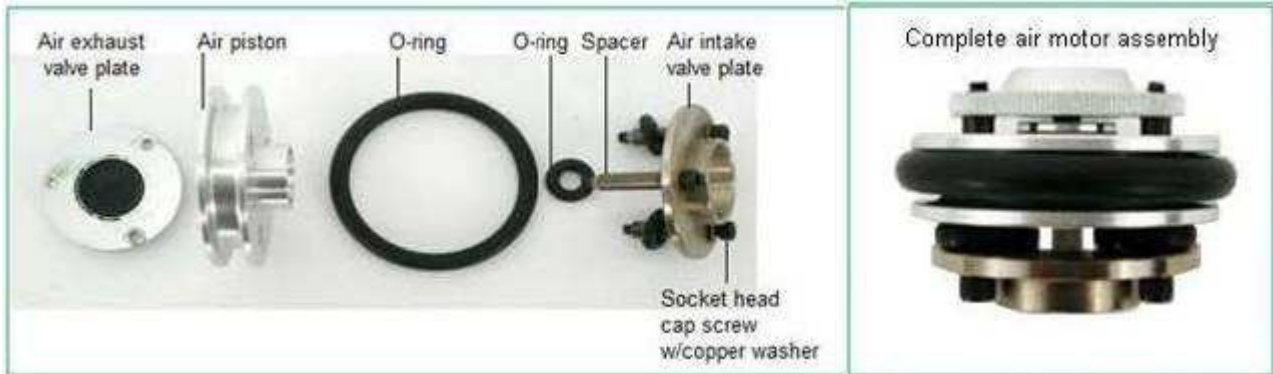

2. Assemble the complete air motor assembly again using threadlocker with washer onto the piston shaft. Hand-tighten only.
3. Slide complete air motor and shaft assembly into the air motor base. Ensure the two square cut gaskets are in the correct position in air cylinder and air cylinder cap. Clamp the air motor base in a vice and use a strap wrench to assemble the air cylinder and the air cylinder cap to the air motor base. Hand-tighten the air cylinder cap and connect piston shaft to displacement rod with flat headed pin, then secure with cotter pin. Install tie rods in outlet housing. Insert piston shaft through the packing's and secure the three lock nuts with threadlocker, then torque to 11-foot pounds tolerance.
4. Secure suction piston assembly to displacement rod by screwing until the threads bottom-out on the hex nut then re-tighten the hex nut.
5. Replace O-ring in outlet housing. Use threadlocker on threads for air cylinder and crew into outlet housing. Hand-tighten air cylinder in place.
6. Use threadlocker on the threads exposed on the cylinder and tighten foot valve in place.

# 4.0 PARTS IDENTIFICATION

## Air motor section

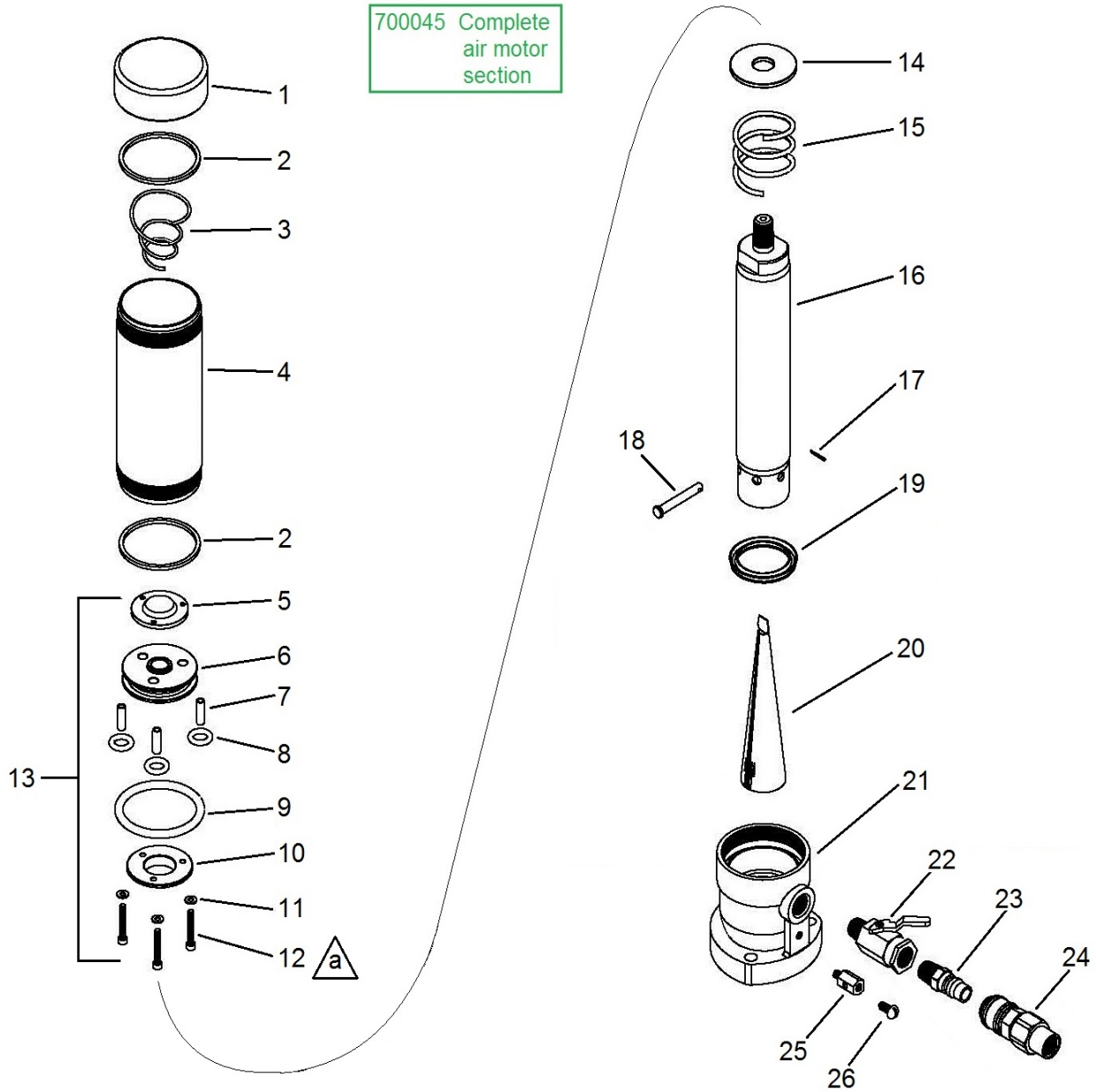

**a** Torque to 10-14 in-lb (1.1-1.6 N•m)

\* Part number 5 (threads) and part number 12 require the use of threadlocker to help ensure they do not come undone.



<b>ITEM</b>	<b>PART NUMBER</b>	<b>DESCRIPTION</b>	<b>QUANTITY</b>
1	500100	Cylinder cap	1
2	500101	Gasket	2
3	500103	Spring	1
4	500102	Cylinder	1
5	500138	Air exhaust valve plate	1
6	500137	Air piston	1
7	500140	Valve plate spacer	3
8	500144	O-ring	3
9	500141	O-ring	1
10	500139	Air intake valve plate	1
11	500143	Copper gasket	3
12	500142	SHCS(6-32X1)	3
13	700014	Air motor assembly (include 5-12)	1
14	500104	Valve washer	1
15	500105	Compression spring	1
16	500106	Piston shaft	1
17	500113	Cotter pin Dia.2X16	1
18	500112	Straight headed pin	1
19	500110	Packing V-Block (NBR)	1
20	500111	Muffler	1
21	500109	Air motor base	1
22	501804	Ball valve	1
23	500370	Air quick connector (M)	1
24	500369	Air quick connector (F)	1
25	500107	Grounding lug	1
26	500108	Screw M5x10	1

**Fluid section**

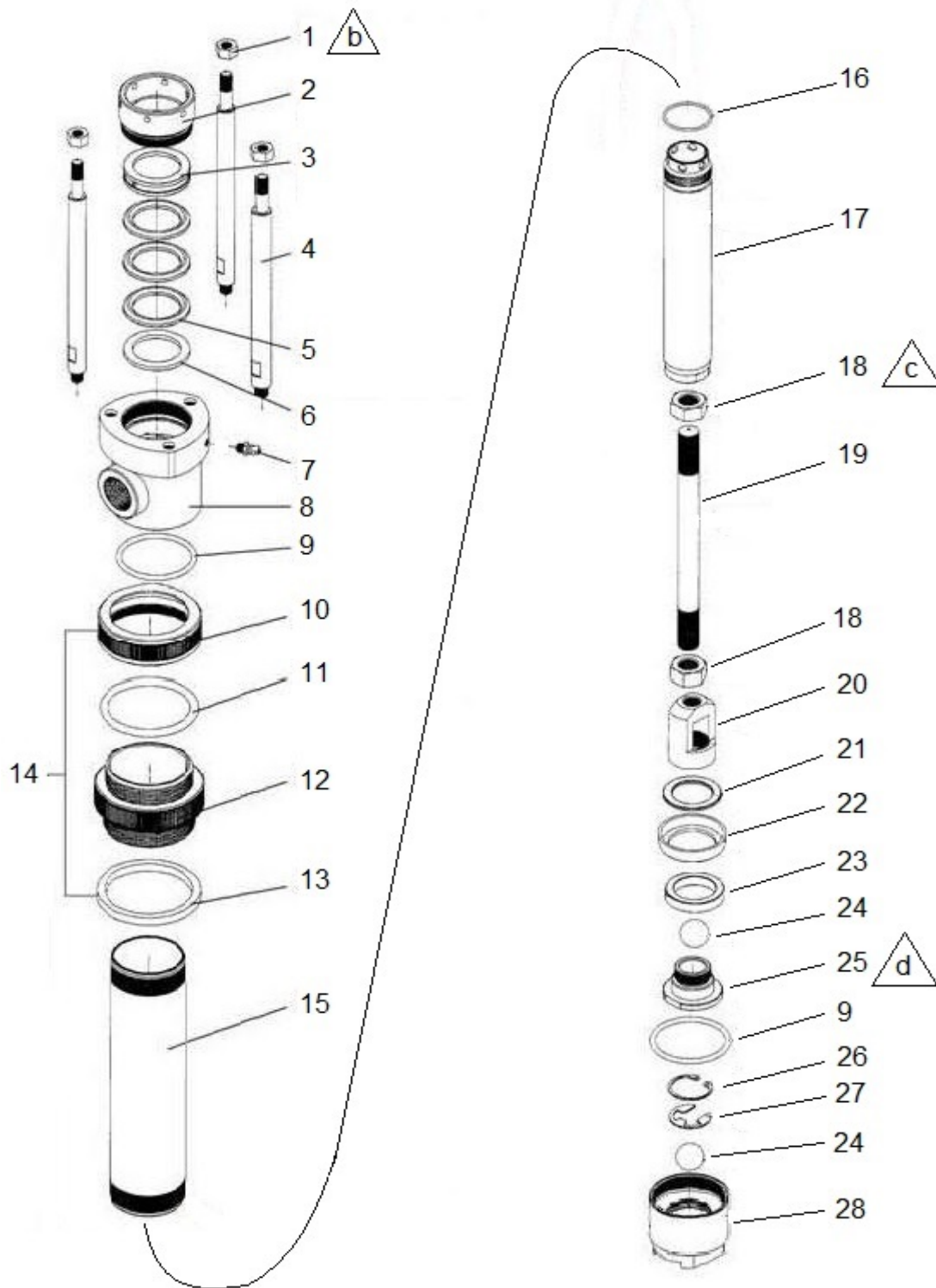

**b** Torque to 11 ft-lb (15 N•m)

**c** Torque to 24 ft-lb (33 N•m)

**d** Torque to 47 ft-lb (64 N•m)

<b>ITEM</b>	<b>PART NUMBER</b>	<b>DESCRIPTION</b>	<b>QUANTITY</b>
1	500115	Lock nut M8	3
2	500152	Packing nut	1
3	500153	Female gland	1
4	500163	Tie rod	3
5	500119	V-Packing	3
6	500154	Male gland	1
7	500122	Grease fitting	1
8	500121	Outlet housing	1
9	500124	O-ring	2
10	500146	Bung adapter cap	1
11	500147	O-ring	1
12	500145	Bung adapter	1
13	500053	Gasket	1
14	700015	Bung adapter assembly (include 10,11,12,13)	1
15	500159	Cylinder	1
16	500114	O-ring	1
17	500155	Displacement rod	1
18	500156	Hex nut	2
19	500157	Connecting rod	1
20	500160	Piston valve housing	1
21	500161	Washer	1
22	500132	Piston cup	1
23	500164	Piston spacer	1
24	500269	Ball	2
25	500158	Pump piston	1
26	500193	Snap ring	1
27	500192	E-clip	1
28	500197	Foot valve	1

## 5.0 REPAIR KITS

<b>601005</b>	<b>Air motor section repair kit</b>		
	Part #	Description	Qty
	500101	Gasket	2
	500110	"V" block packing	1
	500141	O-ring	1
	500144	O-ring	3

<b>601004</b>	<b>Fluid section repair kit, Teflon package</b>		
	Part #	Description	Qty
	500153	Female gland	1
	500154	Male gland	1
	500180	"V" block packing	3
	500181	Piston cup	1

<b>601006</b>	<b>Fluid section repair kit, UHMWPE package</b>		
	Part #	Description	Qty
	500153	Female gland	1
	500154	Male gland	1
	500119	"V" block packing	3
	500132	Piston cup	1

## 6.0 TROUBLE SHOOTING

<b>Problem</b>	<b>Cause</b>	<b>Recommended Solutions</b>
Pump does not move	Air motor stalled	Remove and then reattach the quick disconnect fitting to re-start the air motor.
	Fluid section seized	Make sure the pump has no air or liquid pressure. Remove air cylinder and cap from air motor. See if the piston rod can move up/down or turn. If yes, check for full stroke ability. If piston rod does not move at all, the fluid section is seized.
	Low air supply	A) Increase air supply B) Open air ball valve C) Close bleed valve
Air leak along piston shaft.	Worn packing in fluid section.	Replace packing
Air leaks from piston shaft holes.	Contamination by debris in the air motor piston.	Check O-ring, replace if necessary. Also check the rubber seal to see if it has come apart from the air exhaust valve plate.
Slow operations (Air Motor)	Icing of the air motor. Clogged muffler.	Allow ice built up on the air motor to thaw. Clean or replace the muffler.
Low output both stokes	Restricted fluid hoses. Bad fluid seal in the foot valve or defective piston cup.	Clean, clear or replace hoses. Replace ball and/or piston cup in fluid section.
Low output on up stroke	Bad or damaged piston cup.	Replace piston cup in the fluid section.
Low output on down stroke	Bad or damaged foot valve or ball.	Replace foot valve ball in the fluid section.
Leaking fluid through the packing at air motor base.	Packing damaged or not seated properly.	Replace packing in the fluid section.
	Packing nut too loose.	Tighten packing nut
	Scored or scratched displacement rod.	Replace displacement rod.
Abnormal or rapid operation.	Low or no fluid supply. Broken spring(s) in air motor.	Replenish fluid supply and re-prime the pump.
		Replace springs in the air motor.
Jerky movement of the pump	Packing nut in fluid section too tight.	Stop pump operation. Relieve fluid pressure from drain valve. Loosen packing nut and re-tighten snugly.

## 7.0 TECHNICAL SPECIFICATIONS

### Technical Data

Pressure ratio	1 : 1
Maximum output flow	4 gpm (15.2 lpm )
Maximum fluid pressure	180 psi (12.4bar)
Maximum air input pressure	180 psi (12.4 bar)
Air inlet size	1/4 npt (f)
Fluid outlet size	3/4 npt (f)
Packing / seals	UHMWPE
Rod and cylinder	Stainless steel

### Dimensions

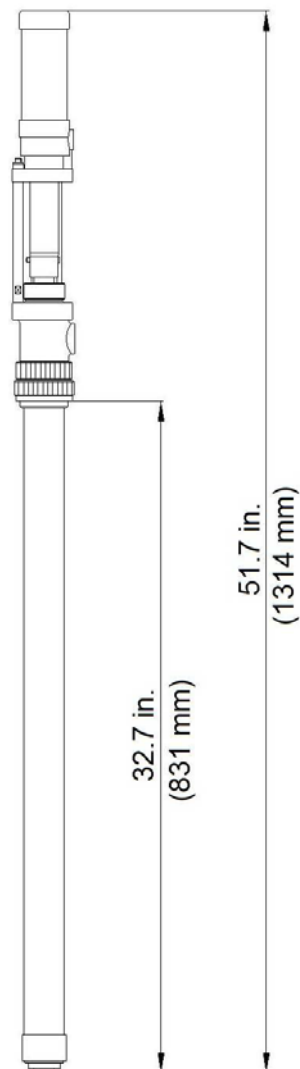

810103

## Performance

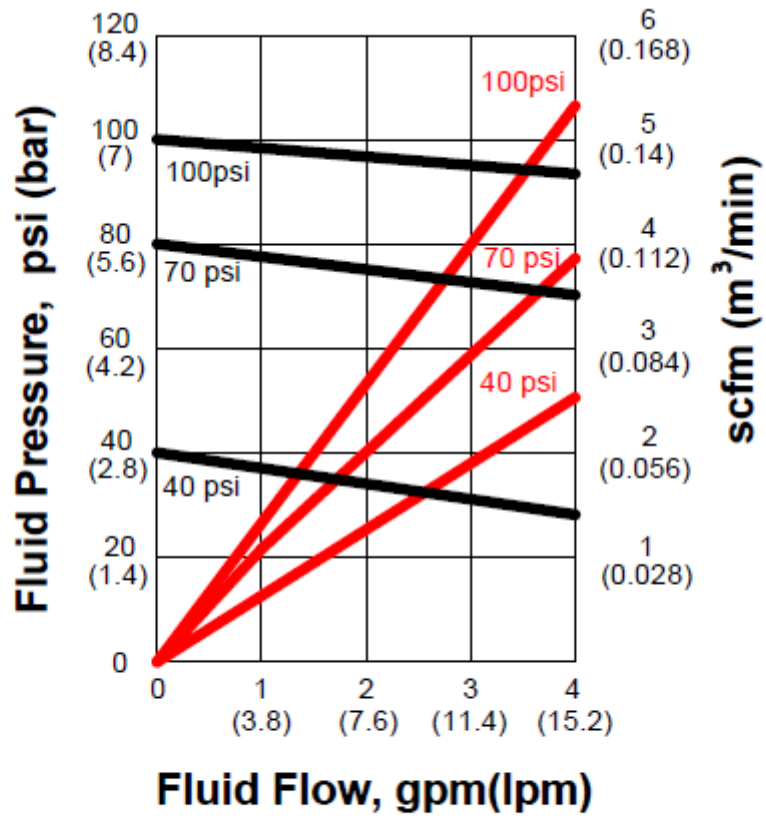

- Fluid Pressure Curves (based on air input pressure 40, 70 and 100 psi)
- Air Consumption Curves (based on air input pressure 40, 70 and 100 psi)

## **8.0 WARRANTY AND DISCLAIMER**

### **Warranty**

International Pump Manufacturing, Inc. (hereafter designated IPM) warrants the equipment it manufactures to be free of defects in materials and workmanship for a period of one (1) year from the date of sale from IPM to an authorized IPM distributor or to the original end user and/or purchaser. IPM will, at its discretion, repair or replace any part of the equipment proven to be defective. This warranty applies only when the equipment is used for the intended purpose and has been installed, operated and maintained in accordance with written operating procedures.

A condition of the warranty is the prepaid return of the equipment to an authorized distributor of IPM who shall provide verification of the warranty claim. IPM will repair or replace free of charge any parts found and verified to be defective or damaged upon receipt of equipment. Shipping will be prepaid for the repaired or replaced parts under warranty. Should inspection of the equipment reveal no defects in material or workmanship repairs will be made at the standard IPM rate, which will include parts, inspection, labor, packaging and shipping.

The warranty does not apply nor shall IPM be liable for damage, operational wear, malfunction of equipment caused by improper installation, misuse, chemical abrasion or corrosion, operator negligence, accident, tampering or altering of equipment, lack of proper maintenance and/or by substitution of non-IPM parts. Additionally, IPM shall not be liable for nor does the warranty apply to operational wear, damage or malfunction caused by incompatibility of accessories, components, structures, equipment or materials not supplied by IPM. The warranty does not apply to nor will IPM be responsible for the improper operation, maintenance, design, manufacture, installation of components, accessories, equipment or structures not supplied by IPM.

The warranty is void unless the Warranty Registration Card is properly completed and returned to IPM within ONE (1) month of the date of the sale.

### **Limitations and Disclaimers**

This warranty is the sole and exclusive remedy for the purchaser. No other warranties, expressed or implied, warranties for fitness of purpose or merchantability, or non-contractual liabilities are made by IPM, including product liability, whether on negligence or a strict liability basis. Liability for directly special or non-contractual damages or loss is expressly excluded and denied. IPM's liability shall in no case exceed the amount of the purchase price.

IPM does not warrant and disclaims implied warranties of merchantability and fitness for a particular purpose, components, accessories, equipment, materials sold but not manufactured by IPM. These parts (valves, hoses, fittings, etc.) are subject to the provisions within the warranty of the actual manufacturer of these items. IPM will provide reasonable assistance with warranty claims on these items.





**3107 142nd Avenue East Suite 106  
Sumner, WA 98390  
U.S.A.**

**TEL: (253) 863 2222 FAX: (253) 863 2223  
Website: [www.ipmpumps.com](http://www.ipmpumps.com)**

**Updated May 2020**