



---

**830802**  
**IP05 SERIES**  
**5:1 RATIO TRANSFER PUMP**  
Operations Manual



---

**IPM, INC.**

Manufactured by International Pump Manufacturing, Inc

# IP05 series

## 5:1 RATIO TRANSFER PUMP

### OPERATING MANUAL and PARTS IDENTIFICATION DRAWINGS

This manual contains IMPORTANT WARNINGS and INSTRUCTIONS. Read and retain for future reference.

INTERNATIONAL PUMP MANUFACTURING, INC.  
3107 142nd Avenue E Suite 106, Sumner, WA 98390  
U.S.A.

TEL: (253) 863 2222

FAX: (253) 863 2223

Website: [www.ipmpumps.com](http://www.ipmpumps.com)

**For Technical Service Call Your Local Distributor**

Copyright 2018 by: International Pump Mfg, Inc.

---

---

**WARNING:** The equipment described herein must only be operated or serviced by properly trained individuals thoroughly familiar with the operating instructions, mechanics and limitations of the equipment.

---

Notice: All statements, information and data given herein are believed to be accurate and reliable but are presented without guarantee, warranty or responsibility of any kind expressed or implied. Statements or suggestions concerning possible use of IPM equipment are made without representation or warranty that any such use is free of patent infringement and are not recommendations to infringe any patent. The user should not assume that all safety measures are indicated or that other measures may not be require

# TABLE OF CONTENTS

1.0 SAFETY WARNINGS.....	4
2.0 INSTALLATION.....	9
3.0 OPERATION.....	10
4.0 MAINTENANCE.....	11
5.0 PART IDENTIFICATION.....	16
6.0 REPAIR KITS.....	20
7.0 TROUBLESHOOTING.....	21
8.0 TECHNICAL SPECIFICATIONS.....	22
9.0 WARRANTY AND DISCLAIMER.....	24

## **1.0 SAFETY WARNINGS**

Please read and observe all warnings contained in this operation manual before any attempt to operate the equipment.

### **Warning**

To reduce the risk of static sparking or splashing fluid in the eyes or on the skin, follow the [\*Procedure for Pressure Relief\*](#) (page 5) before flushing.

For your safety, read the [\*Hazard from Fire or Explosion\*](#) (page 6) before flushing and follow all the listed recommendations.

### **Misuse of Equipment**

Misuse of equipment can cause serious bodily injury. Use the equipment only for its intended purpose and do not attempt to modify it in any way. Care should be taken to prevent over pressurization of the pump, hose lines and accessories connected to it. Use only IPM designated parts for re-building or repairing this equipment. Use the pump only with compatible fluids. Improper use of this equipment could result in fluid being sprayed on the skin or in the eyes of user, serious bodily injury, property damage, fire or explosion.

Daily maintenance inspection should be made on pumps and equipment and all worn or damaged parts should be re-placed immediately. Do not use pumps, components or hose lines as leverage to move equipment to avoid damage and injury.

Do not alter this equipment as doing so could cause it to function incorrectly and/or cause serious injury. Altering this equipment in any way will also void all warranty guarantees from the manufacturer.

### **Material & Fluid Compatibility**

Always ensure the chemical compatibility of the fluids and solvents used in the fluid section of these pumps, hoses other components. Check the chemical manufacturer's data sheets and specification charts before using fluids or solvents in this pump to ensure compatibility with pumps, inner hose lining and outer hose covering.

### **Pressurized Hoses**

Because the hoses are pressurized, they can present a danger should the fluid escape due to damage, worn parts or general miss-use. Escaping fluid can splash or spray operator, causing serious bodily injury and/or damage to equipment and property. Ensure that the hoses do not leak or rupture due to wear, misuse or damage.

Before each use, ensure that the fluid couplings are tight, and all clips/pins/plugs are secured. Inspect the entire length of hose for wear, cuts, abrasions, bulging cover and/or loose connections. These conditions may cause the hose to fail and result in splashing or spraying of chemicals on the skin or in the eyes of operator and cause serious injury and/or property damage.

## **Pressure Specification**

The maximum working pressure of this equipment for fluids is 900 PSI (62 bar) with a maximum incoming air pressure tolerance of 180 PSI (12.4 bar). Ensure all equipment and accessories used with this pump are rated to withstand the maximum working pressure of this pump. Never exceed the maximum working pressure of the pump, hose lines or any other components attached to the pump itself.

## **Procedure for Pressure Relief**

In order to avoid the risk of serious injury to operators from splashing/spraying chemicals, the following safety procedures should be used. This procedure should be used when shutting down the pump, performing general maintenance, repairing a pump or other components of the system, replacing components or when pumping operation is ceased.

1. Close the air valve to the pump.
2. Use the air bleed down valve to relieve the air pressure in the system.
3. Relieve the fluid pressure by holding a grounded metal pail in contact with the metal part of the fluid dispense valve and slowly opening the valve.
4. With a container ready to catch the fluid, open the drain valve (see INSTALLATION, page 9).
5. It is a good practice to leave the drain valve open until it is time to dispense fluid again

If you are unsure that the fluid pressure has been relieved due to a blockage in a component or a hose, carefully relieve the pressure by carefully loosening the hose end coupling to allow the fluid pressure to escape slowly. After the pressure has been relieved, the fitting can then be removed, and any blockages removed.

## **Flush the Pump Before Initiating Operation**

1. The pump is tested with lightweight DOP oil, which is left in to protect the pump parts. If the fluid you are pumping may become contaminated by oil, flush oil from pump with a compatible solvent before use. Follow the flushing instructions below.
2. When pumping fluids that set up or solidify, flush the system with a compatible solvent as often as necessary to remove build-up of solidified chemicals in the pump or hoses.
3. If the pump is being used to supply a circulating system, allow the solvent to circulate through the entire system for at least 30 minutes every 48 hours or more often if necessary, to prevent settling and solidification of chemicals.
4. Always fill the wet-cup 1/2 full of throat seal liquid (TSL) or compatible solvent to keep the fluid from drying on the displacement rod and damaging pump throat packing.
5. Lubricate the throat packing frequently, when you are pumping a non-lubricating fluid or are shutting down for more than one day.

6. Once a pump is committed to a particular chemical, it is good practice to identify which chemical a particular pump is designated for to eliminate the possibility of mix up and contamination.

## **Lubrication**

Transfer pump should be lubricated daily. Drain moisture from the air regulator. To manually lubricate the motor, disconnect the air lines at the motor and place approximately 10 of oil in the **air inlet**. Reconnect the air line and turn on the air to blow oil into the motor. Also keep the wet-cup filled with Throat Seal Liquid (TSL) or compatible solvent. This will reduce maintenance and prolong the packing life. Adjust the packing nut weekly so it is just tight enough to prevent leakage but do not over-tighten as this will restrict pump operation. Always follow the [\*Procedure for Pressure Relief\*](#) (page 5) before adjusting the packing nut.

## **Shut Down & Care of Pump**

For overnight shut down, follow the [\*Procedure for Pressure Relief\*](#) (page 5). Always stop the pump at bottom of the stroke to prevent the fluid from drying on the exposed displacement rod and damaging the throat packing.

## **Hazards from Fire or Explosion**

Hazards exist where sparks can ignite vapors or fumes from combustible chemicals or other hazardous conditions exist such as explosive dust, etc. These sparks can be created from plugging in or unplugging an electrical supply cord or from the static electricity generated by the flow of fluid through the pump and hose.

Every part of the equipment must be properly grounded to prevent static electricity from generating a spark and causing the pump or system to become hazardous. These sparks can cause property and equipment damage and serious bodily injury. Ensure that the pump and all components and accessories are properly grounded and that electrical supply cords are not plugged in or unplugged when these hazards exist.

Should any evidence of static electricity (sparks or small shocks while in contact with the equipment) exists, discontinue the operation immediately. Investigate the source of the static electricity and correct the grounding problem. Do not use the system until the grounding problem is repaired.

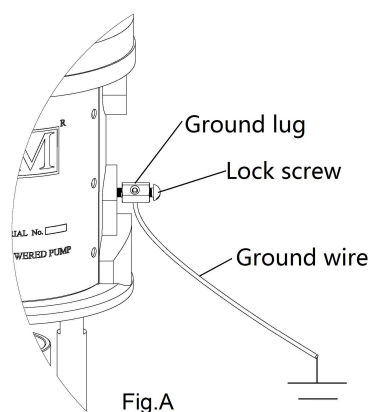

## **Pump and Component Grounding Procedures**

Always use the following procedures for grounding the pump. Loosen the lock screw to allow insertion of one end of a minimum sized 12-gauge wire into the bore hole of the grounding lug. Insert wire and tighten the lock screw securely. Secure the other end of the ground to a true earth ground. Grounding of the pump and all components is necessary to minimize the possibility of sparks due to static electricity. Grounding must be in compliance with local electrical codes. Check with the local authorities for requirements in your area and with the type of equipment being used.

Grounding of the pump and all other dispensing equipment is necessary to minimize the possibility of sparks due to static electricity. Grounding must be in compliance with local electrical codes. Check with the local authorities for requirements in your area and with the type of equipment being used. Ensure that all the following equipment is grounded:

1. Air compressor: Follow the grounding procedures as recommended by the manufacturer.
2. Air hoses: Use grounded air hoses.
3. Fluid container used to supply the system: Grounding must be done according to local codes.
4. Pump: Follow the procedures included referring to in Fig. A.
5. Fluid Hoses: Use grounded fluid hoses.
6. Dispensing Valve: The valve must be metal to conduct through the fluid hose to the pump which must be properly grounded.
7. Dispensing Point: Grounding must be done according to local codes.
8. Solvent Containers: Grounding must be done according to local codes. Use metal conductive pails that are properly grounded.
9. Dispensing, cleaning or pressure release: Maintain conductivity by firmly holding the metal part of the dispensing valve to the side of a grounded metal container.

## **Hose Grounding**

It is very important that the hoses used for both air and the fluid be a grounding type and that this ground continuity is maintained. Regular checks of the hose ground resistance (with a resistance meter using a suitable range) and a comparison to the Manufacturer's Specification will ensure the ground is within specifications. If it is not within specified limits it should be replaced immediately.

## **Solvent Cleaning**

While cleaning the system with solvent, hold the metal part of the dispensing valve in contact with a grounded metal pail to minimize the possibility of splashing fluid on the skin or in the eyes or static sparks. Use low fluid pressure for additional safety.

## **Hazards from Moving Parts**

Use the [\*Procedure for Pressure Relief\*](#) (page 5) to prevent the pump from starting unintentionally when not desired. Take care that moving parts present a pinching hazard to fingers or other body parts. Stay clear of these moving parts when starting or operating the pump. Never operate the pump with the air motor plate removed.

## **Safety Standards**

Safety standards have been established by the United States Government under the Occupational Safety and Health Act. These standards should be consulted as they apply to the hazards and type of equipment being used.

## 2.0 INSTALLATION

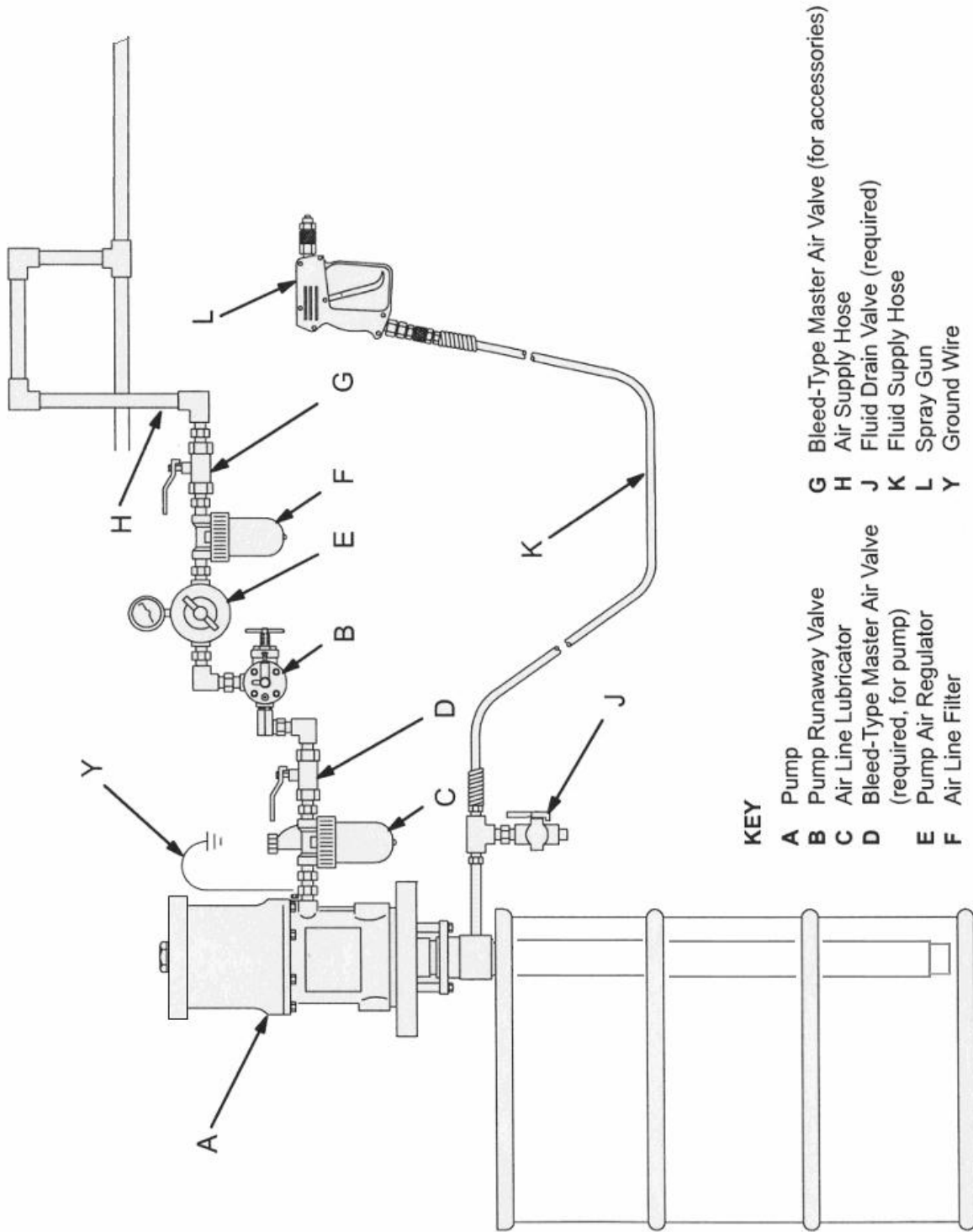

Figure B Typical installation

## **3.0 OPERATION**

### **Start Up and Adjustment of the Pump**

1. Using Fig. B (page 9) as a reference, shut off main air supply, master air valve and fluid drain valve. Do not install the spray tip yet.
2. Insert suction tube into the fluid supply drum for wall mount set-up or the pump itself for drum length unit.
3. Hold the spray gun firmly to the side of the supply drum and hold the trigger open.
4. Carefully open the pump's bleed-type master air valve.
5. Slowly open the main air supply until the pump starts cycling, which will be at about 40 PSI (2.8 bar).
6. Cycle the pump slowly until all the air is purged to ensure the pump and hoses are fully primed.
7. Release the spray gun trigger and lock the safety. The pump should completely stall under pressure when the trigger is released.
8. With the pump and lines primed and adequate air pressure and volume supplied the pump will start and stop as the spray gun is opened and closed.
9. To relieve the pressure, follow the [\*Procedure for Pressure Relief\*](#) (page 5), then install the tip guard and spray tip in the gun.
10. For optimum efficiency, use an adequately sized air regulator to control the pump speed and fluid pressure. Always use the lowest air pressure necessary to get desired results. Higher pressures waste fluid, create erratic spray patterns and cause premature wear of the pump packings and nozzles.
11. Into a grounded metal container, slowly open the dispensing valve. Ensure metal-to-metal contact between the container and the valve.

**Note:** The pump should never be allowed to run dry of fluid. When drum runs empty the pump speed will increase dramatically and equipment damage will occur. During operation, should the pump be found running too fast stop it immediately and check the fluid supply. If air has gotten into the system, a priming procedure should be done. Ensure that all air has been expelled from the lines before resuming normal operations. Flush the pump or leave it filled with a suitable solvent when not in use. Always follow the [\*Procedure for Pressure Relief\*](#) (page 5) should the pump be put away for any period of time or during system shut off at the end of the day.

## 4.0 MAINTENANCE

### Disconnecting the Fluid Section

1. Flush the pump if possible. Stop the pump at the bottom of its stroke. Follow the [Procedure for Pressure Relief](#) (page 5).
2. Disconnect the air and fluid hoses. Remove the pump from its mounting. Note the relative position of the pump's fluid outlet (o) to the air motor's air inlet (i).
3. Unscrew the tie rod lock nuts (8) from the tie rods (7). Remove the cotter pin (4). Unscrew the displacement rod (3) from the air motor (1). Carefully pull the displacement pump (6) off the air motor (1). Inspect the o-ring (2). See Fig. C.

### Reconnecting the Fluid Section

1. Lubricate the o-ring (2) and check that it is in place on the displacement rod (3). Orient the pump's fluid outlet (o) to the air motor's air inlet (i) as was noted in step 2 under [Disconnecting the Fluid Section](#). Position the displacement pump (6) on the tie rods (7). See Fig. C.
2. Screw the locknuts (8) onto the tie rods (7) loosely. Screw the displacement rod (3) into the shaft of the air motor (1) until the pin holes in the rod and shaft align. Install the cotter pin (4).
3. Apply thread sealant to the pump fluid outlet (o) and the threads of the fluid hose. Mount the pump and reconnect all hoses. Reconnect the ground wire if it was disconnected during repair. Tighten the packing nut/wet-cup (5) so it is just snug-no tighter. Fill the wet-cup with Throat Seal Liquid or compatible solvent.
4. Tighten the tie rod locknuts (8) evenly, and torque as shown in Fig. C.
5. Start the pump and run it at about 40 psi (0.3 Mpa, 2.8 bar) air pressure, to check that it is operating properly.
6. Check for fluid leakage at the packing nut (5). Follow the [Procedure for Pressure Relief](#) (page 5) before tightening the packing nut/wet-cup.

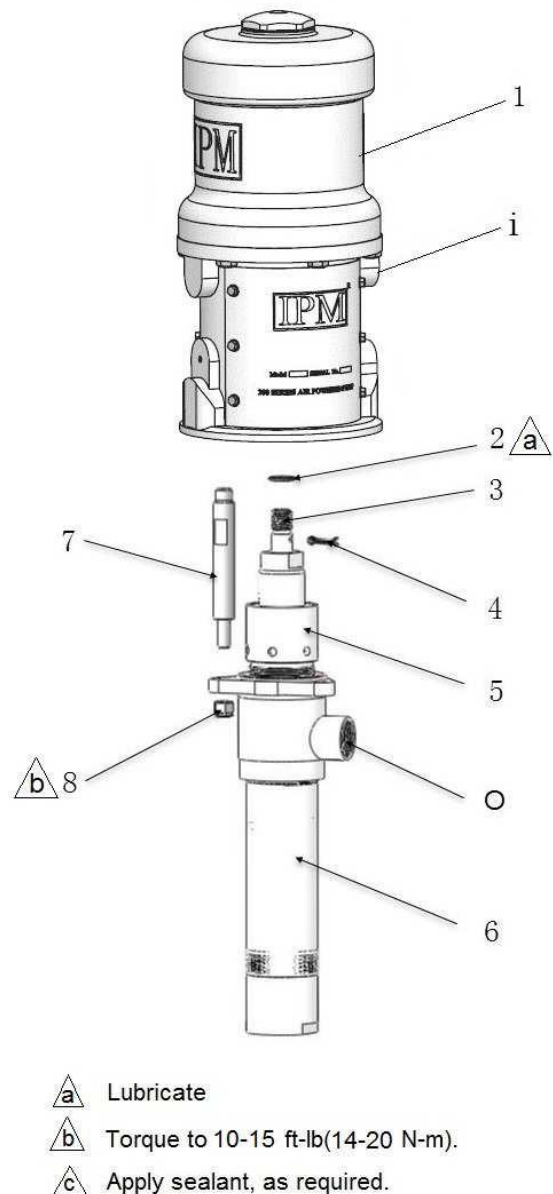

**Fig. C**

### Disassembly the Air motor

1. Disconnect the air hose from the motor. If necessary, disconnect the motor from the pump. Clamp the air motor base in a vise.
2. Manually push up on the piston rod to move the piston assembly to the top of its stroke. Unscrew the cap nut (1) from the air cylinder (3). Pull up on the cap nut. Grip the trip rod (13) with padded pliers and screw the cap nut off the trip rod. See Fig. D.
3. Remove the six screws (27) holding the air cylinder (3) to the base (30). Carefully pull the cylinder straight up off the piston. See Fig. D.
4. Use a screw driver to push down on the trip rod yoke (6) and snap the toggle assemblies (7/16) down. See Fig. E. Remove the lockwires (8) from the adjusting nuts (9) of the transfer valves. Screw the top nuts (9) off. Screw the valve stems (12) out of the grommets (10) and lower adjusting nuts (9). Take the valve poppets (11) off the stems and squeeze them firmly to check for cracks.
5. Grip the toggle rockers (7) with a pliers. Compress the springs (16) and swing the toggle assembly (7/16) up and away from the piston lugs, and remove the parts. Check that the valve actuator (4) is supported by the spring clips (18), but slides easily into them. See Fig. E.
6. Remove the trip rod yoke (6), valve actuator (4) and trip rod (13). Check the exhaust valve poppets (5) for cracks.
7. Pull the piston (19) up out of the base (30) and inspect the piston o-ring (20) and the o-ring in the base casting.

### Reassembly the Air motor

1. Clean all the parts carefully in a compatible solvent and inspect for wear or damage. Use all the repair kit parts during reassembly and replace other parts as necessary.
2. Check the polished surfaces of the piston, piston rod and cylinder wall for scratches or wear. A scored rod will cause premature packing wear and leaking.
3. Lubricate all parts with a light, waterproof grease.
4. Be sure the o-rings are in place. Slide the piston rod down through the throat bearing and lower the piston (19) into the air motor base (30).
5. Pull the exhaust valve poppets (5) into the valve actuator (4) and clip off the top part shown with dotted lines. See Fig. E.
6. Install the transfer valve poppets (11) onto the valve stems (12), then reassemble the valve stems (12), bottom adjusting nuts (9), grommets (10), and top adjusting nuts (9) on the piston (19). Assemble the trip rod (13), valve actuator (4), trip rod yoke (6) and toggle assemblies (7/16) on the piston. See Fig. E.
7. Set gap on inlet valve using the .125 in. (3.18mm) side of gauge. Rotate valve stem (12) until snug against gauge, then back off until valve stem slot is lined up with wire holes in valve nut (9) (do not back off more than 1/2 turn). See Fig. E. Install lock wires (8) in the adjusting nuts (9).
8. Snap the toggle assemblies (7/16) to the up position. Reinstall the cylinder (3) and hold the trip rod (13) in place with padded pliers. Apply a thread locking compound to the threads of the trip rod (13) and assemble the cap nut (1) to the trip rod (13). Torque the cap nut (1) to 60 lb-in (6.8N-m). Install cap nut (1) into cylinder (3).
9. Before remounting the pump, connect an air hose and run the pump slowly, at about 40 psi (2.8 bar) to ensure that it operates smoothly.
10. Reconnect the ground wire before regular operation of the pump.

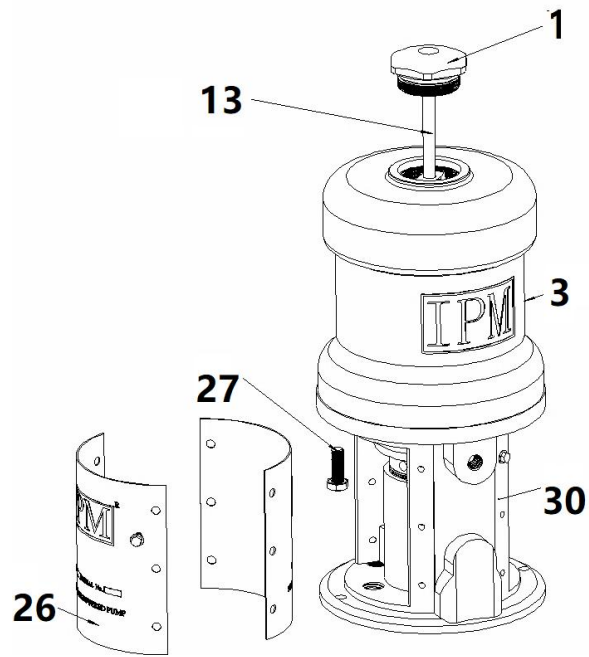

Fig D

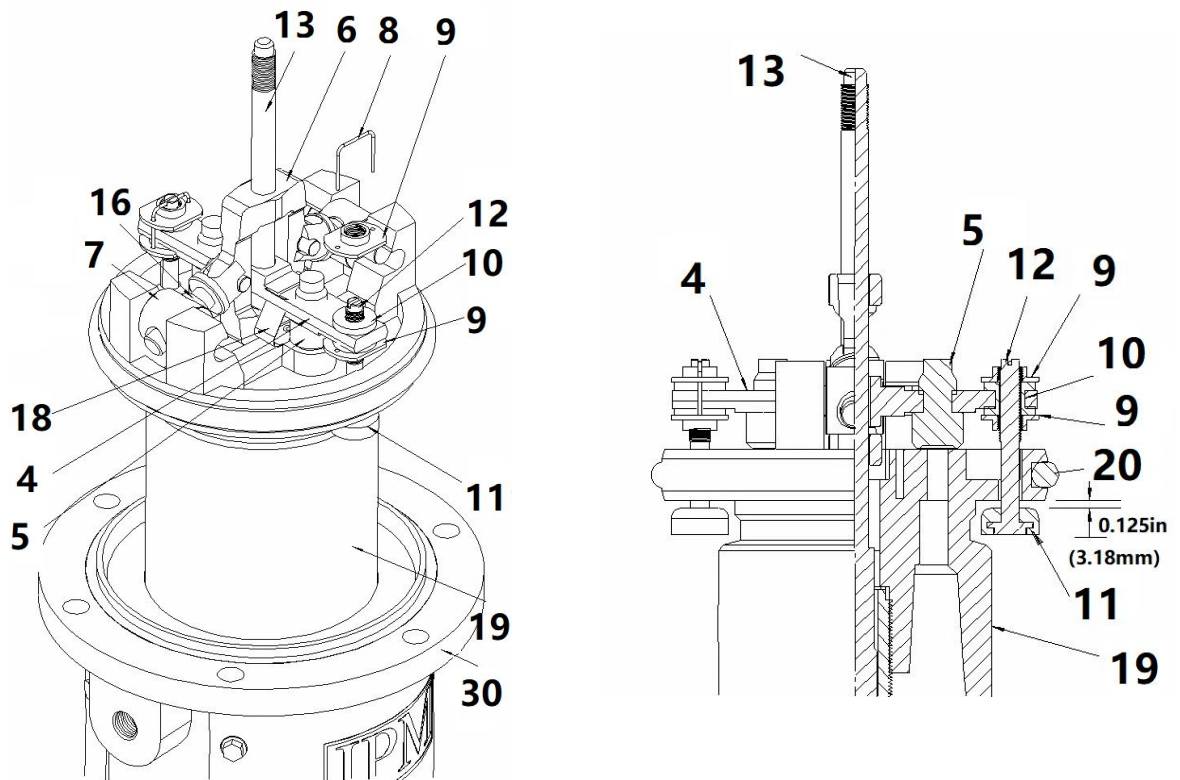

Fig E

## **Disassembling the Fluid Section**

When disassembling the pump, lay out all removed parts in sequence, to ease reassembly. Refer to Fig. F.

Clean all the parts thoroughly when disassembling. Check them carefully for damage or wear, replacing parts as needed.

1. Remove the displacement pump from the air motor as explained on the previous page.
2. Unscrew the foot valve housing (20) from the cylinder (24). See Fig. F.
3. Remove the o-ring (21), ball stop pin (18) and ball (19) from the foot valve housing (20).
4. Loosen the packing nut (5). Push the displacement rod (3) down as far as possible, then pull it out the bottom of the cylinder (24).
5. Secure the flats of the displacement rod (3) in a vise. Using a wrench on the flats of the piston mounting stud (23), screw the piston off the rod. Remove one cotter pin (15) and the ball stop pin (16), taking note which set of holes it is in. Then remove the ball (17).
6. Place the flats of the piston mounting stud (23) in a vise and unscrew the piston stud (22). Remove the piston packings (27, 28), glands (26, 29), washer (25).
7. Remove the packing nut (5), throat packings (11, 12), and glands (10, 13) from the outlet housing (9).
8. Inspect all parts for damage. Clean all parts and threads with a compatible solvent before reassembling. Inspect the polished surfaces of the displacement rod (3) and cylinder (24) for scratches, scoring or other damage, which can cause premature packing wear and leaking. To check, run a finger over the surface or hold the part up to the light at an angle. Be sure the ball seats of the piston (22) and foot valve housing (20) are not chipped or nicked. Replace any worn or damaged parts.

## **Reassembling the Fluid Section**

1. See Fig. F. Lubricate the throat packings and install them in the outlet housing (9) one at a time as follows, with the lips of the v-packings facing down: the male gland (13), the v-packings (11,12), and the female gland (10). Apply thread lubricant and install the packing nut (5) loosely.
2. If you removed the cylinder (24), apply thread lubricant and reinstall it in the outlet housing (9), making sure to replace the o-ring (14).
3. See Fig. F. Lubricate the piston packings and install them one at a time in the following order, with the lips of the v-packings facing up: the female gland (29), the v-packings (27,28), the male gland (26), and the washer (25).
4. Apply thread sealant and screw the piston stud (22) onto the piston mounting stud (23). Torque to 50-70 ft-lb (68-95 Nm). Install the piston ball (17) on the piston seat. Slide the ball stop pin (16) into the desired set of holes, and secure with the cotter pin (15).
5. Place the flats of the displacement rod (3) in a vise. Apply sealant and screw the piston assembly onto the displacement rod. Torque to 50-70 ft-lb (68-95N•m).
6. Insert the displacement rod (3) into the bottom of the cylinder (24), being careful not to scratch the cylinder. Push the rod straight up until it protrudes from the packing nut (5).
7. Install the ball (19), o-ring (21), and ball stop pin (18) in the foot valve housing (20). Apply thread sealant to the foot valve housing and cylinder (24) and screw the foot valve housing onto the cylinder.
8. Reconnect the displacement pump to the air motor as explained on the previous page.

Detail A: Throat Packing

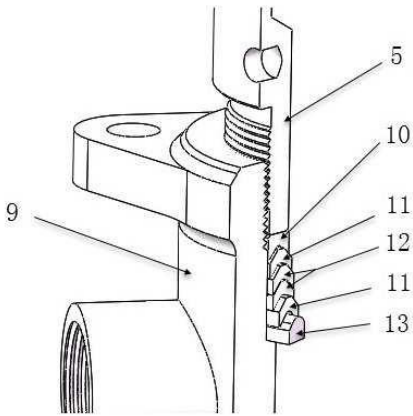

**NOTE:** Lips of v-packings must face down.

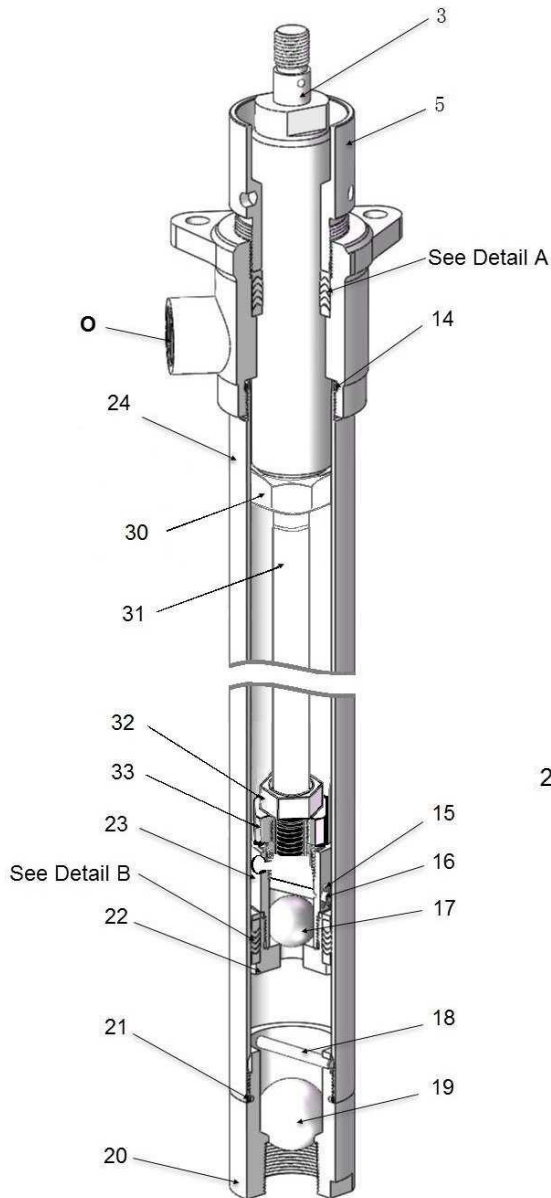

**Fig. F**

Detail B: Piston Packings

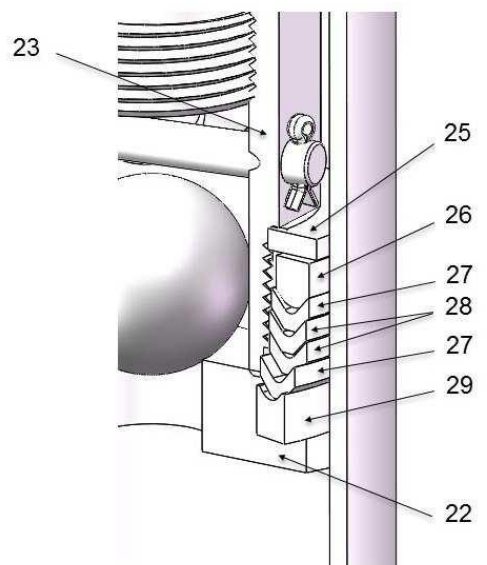

**NOTE:** Lips of v-packings must face up.

# 5.0 PART IDENTIFICATION

## Air Motor Section

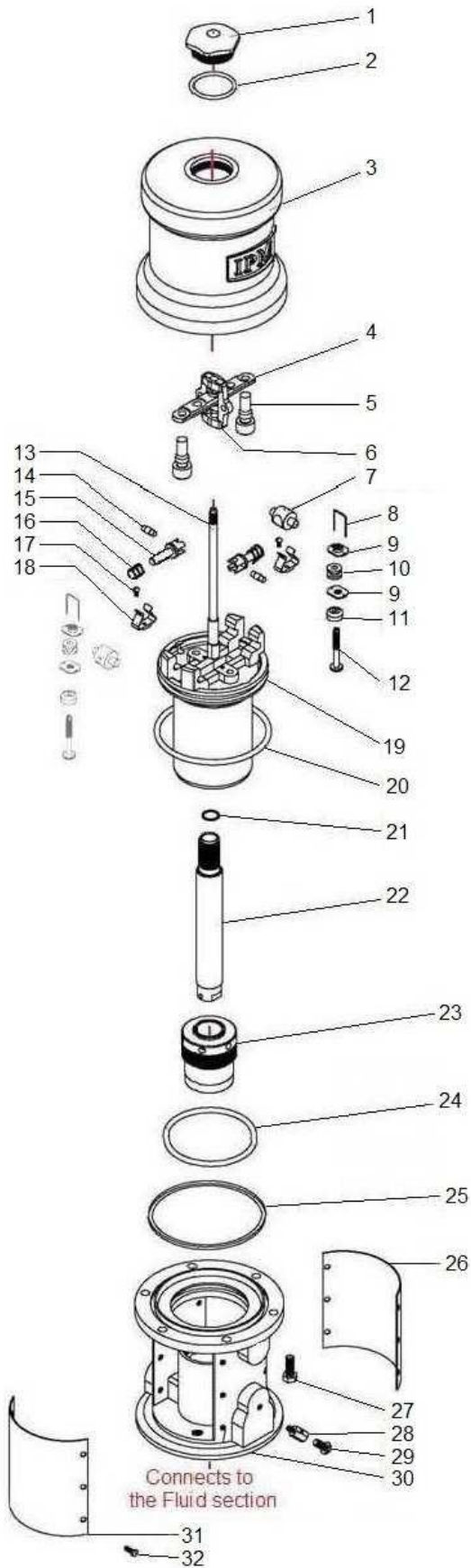

<b>ITEM</b>	<b>PART NUMBER</b>	<b>DESCRIPTION</b>	<b>QUANTITY</b>
1	500300	Cap nut	1
2	500206	O-ring	1
3	500301	Air cylinder	1
4	500303	Actuator valve	1
5	500304	Poppet valve	2
6	500312	Trip rod yoke	1
7	500313	Rocker toggle	2
8	500307	Locking wire	2
9	500309	Adjusting nut	4
10	500308	Grommet	2
11	500311	Poppet valve	2
12	500310	Stem valve	2
13	500302	Trip rod	1
14	500316	Toggle pin	2
15	500314	Toggle arm	2
16	500315	Spring	2
17	500305	Screw	2
18	500306	Spring clip	2
19	500320	Piston	1
20	500317	O-ring	1
21	500321	Copper gasket	1
22	500324	Piston rod	1
23	700032	Bearing Housing Assembly	1
24	500318	O-ring	1
25	500319	Gasket	1
26	500351	Identification plate	1
27	500322	Hex head screw	6
28	500107	Ground lug	1
29	500108	Screw	1
30	500323	Base	1
31	500352	Warning plate	1
32	500325	Hex head screw	12

# Fluid Section

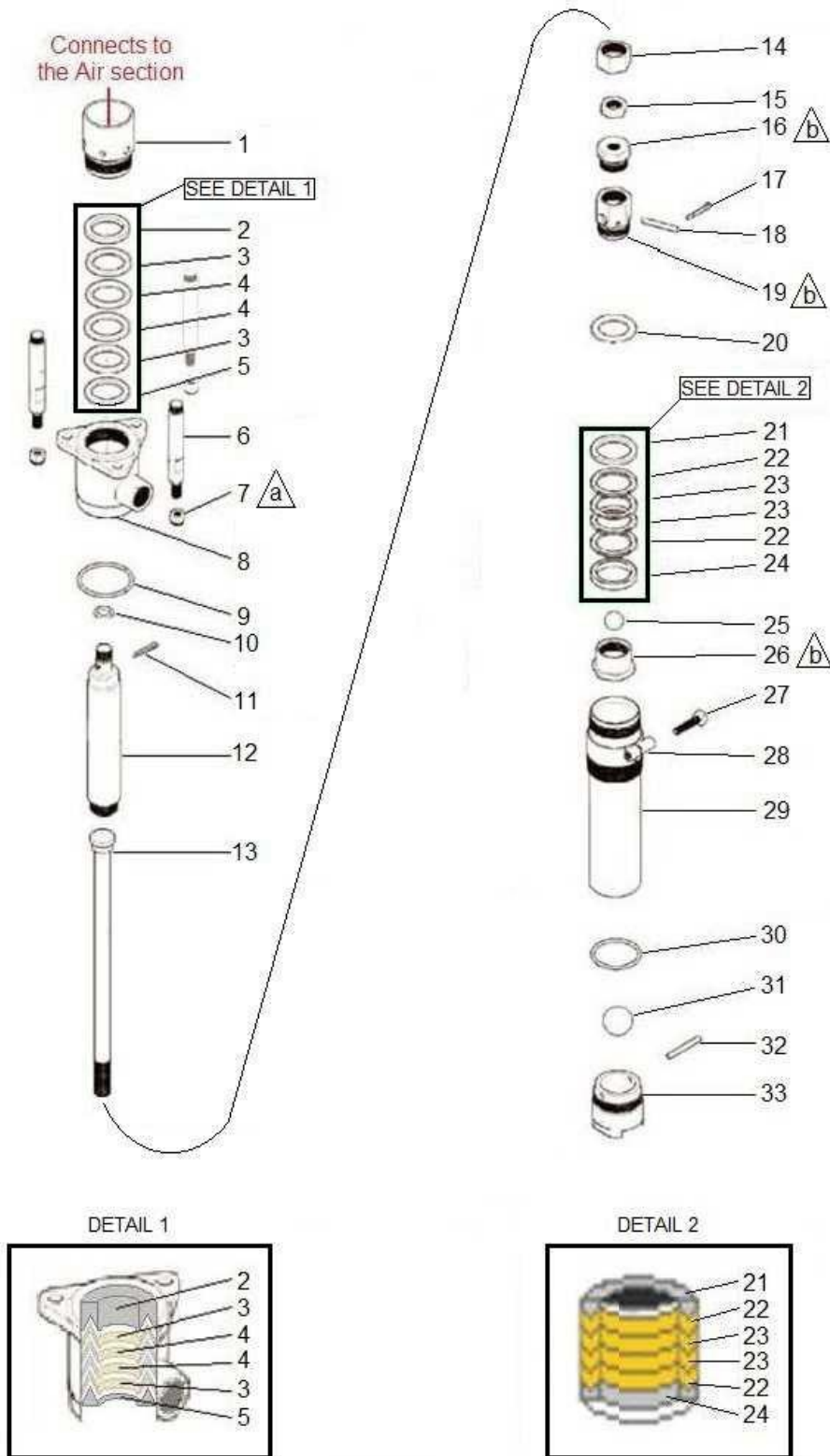

**△ a** Torque to 10-15 ft-lbs (14-20 N•m)

**△ b** Torque to 50-70 ft-lbs (68-95 N•m)

<b>ITEM</b>	<b>PART NUMBER</b>	<b>DESCRIPTION</b>	<b>QUANTITY</b>
1	500450	Packing nut	1
2	500451	Female throat gland	1
3	500421	Throat V-packing	2
4	500422	Throat V-packing	2
5	500452	Male throat gland	1
6	500447	Tie rod	3
7	500448	Locking nut	3
8	500424	Outlet housing	1
9	500425	O-ring	1
10	500402	O-ring	1
11	500449	Cotter pin	1
12	500453	Displacement rod	1
13	700033	Connecting rod	1
14	500456	Coupling nut	1
15	500457	Jam nut	1
16	500458	Connecting rod adaptor	1
17	500461	Cotter pin	1
18	500460	Ball stop pin	1
19	500459	Piston mounting stud	1
20	500462	Piston washer	1
21	500463	Male piston gland	1
22	500375	Piston V-packing	2
23	500376	Piston V-packing	2
24	500464	Female piston gland	1
25	500269	Ball	1
26	500374	Piston stud	1
27	500472	Hex head bolt	1
28	700035	Bung adaptor	1
29	500493	Cylinder	1
30	500066	O-ring	1
31	500466	Ball	1
32	500468	Ball stop pin	1
33	500492	Foot valve	1

## 6.0 REPAIR KITS

<b>601001</b>	<b>Air motor section repair kit</b>		
	Fits: 830802,830803		
	Components include		
	Part #	Description	Qty
	500304	Poppet valve	2
	500307	Locking wire	2
	500308	Grommet	2
	500309	Adjusting nut	4
	500310	Stem valve	2
	500311	Poppet valve	2
	500317	O-ring	1
500318	O-ring	1	

<b>601072</b>	<b>Fluid section repair kit</b>		
	Fits: 830802,830803,840902,840903		
	Components include		
	Part #	Description	Qty
	500269	Ball	1
	500402	O-ring	1
	500421	V-packing	2
	500422	V-packing	2
	500425	O-ring	1
	500375	V-packing	2
	500376	V-packing	2
	500449	Cotter pin	1
	500451	Female gland	1
	500452	Male gland	1
	500460	Ball stop pin	1
	500461	Cotter pin	2
	500462	Piston washer	1
	500463	Male piston gland	1
	500464	Female piston gland	1
	500466	Ball	1
500468	Ball stop pin	1	
500066	O-ring	1	

## 7.0 TROUBLESHOOTING

<b>Problem</b>	<b>Causes</b>	<b>Recommended Solutions</b>
Pump does not operate.	Air supply or pressure is inadequate. Air lines restricted.	Increase air pressure. Check for any restrictions in air line.
	Dispensing valve is not open or clogged.	Open and/or clear foot valve.
	Clogged fluid lines, valves, hoses or damaged air motor.	Follow pressure relief procedure to clear obstruction.  Service air motor. Replace parts as necessary.
	Depleted or exhausted fluid supply.	Refill fluid. Prime system or flush it.
	Worn or damaged air motor gasket, packing, seal, etc	Service air motor. Replace parts as necessary.
Non-stop air exhaust.	Intake valve or packing worn off.	Replace worn parts
Erratic pump operation.	Intake valve is not completely closed.	Clear obstruction and service pump. Replace parts as necessary.
	Held open or worn intake valve.	Clear obstruction and service pump. Replace parts as necessary.
Low output on upstroke.	Held open or worn piston valve.	Clear obstruction and service pump. Replace parts as necessary.
Low output on down stroke.	Restriction in air lines or air pressure low.	Increase air pressure or supply.
	Closed or clogged valves.	Open valve or clear valve.
Low output on both strokes.	Fluid supply is insufficient or exhausted.	Refill fluid. Prime system or flush it.
	Obstructions in fluid lines, hoses, valves, etc.	Follow pressure relief procedure, then clear obstruction.

# 8.0 TECHNICAL SPECIFICATIONS

## Technical Data

Pressure ratio	5 : 1
Maximum fluid continuous flow	2.5 gpm (9.5 lpm)
Maximum fluid pressure	900 psi (62 bar)
Maximum air input pressure	180 psi (12.4 bar)
Air inlet size	3/8 npt (f)
Fluid outlet size	3/4 npt (f)
Packing / seals	PTFE, UHMWPE
Rod and cylinder	Stainless steel

## Performance

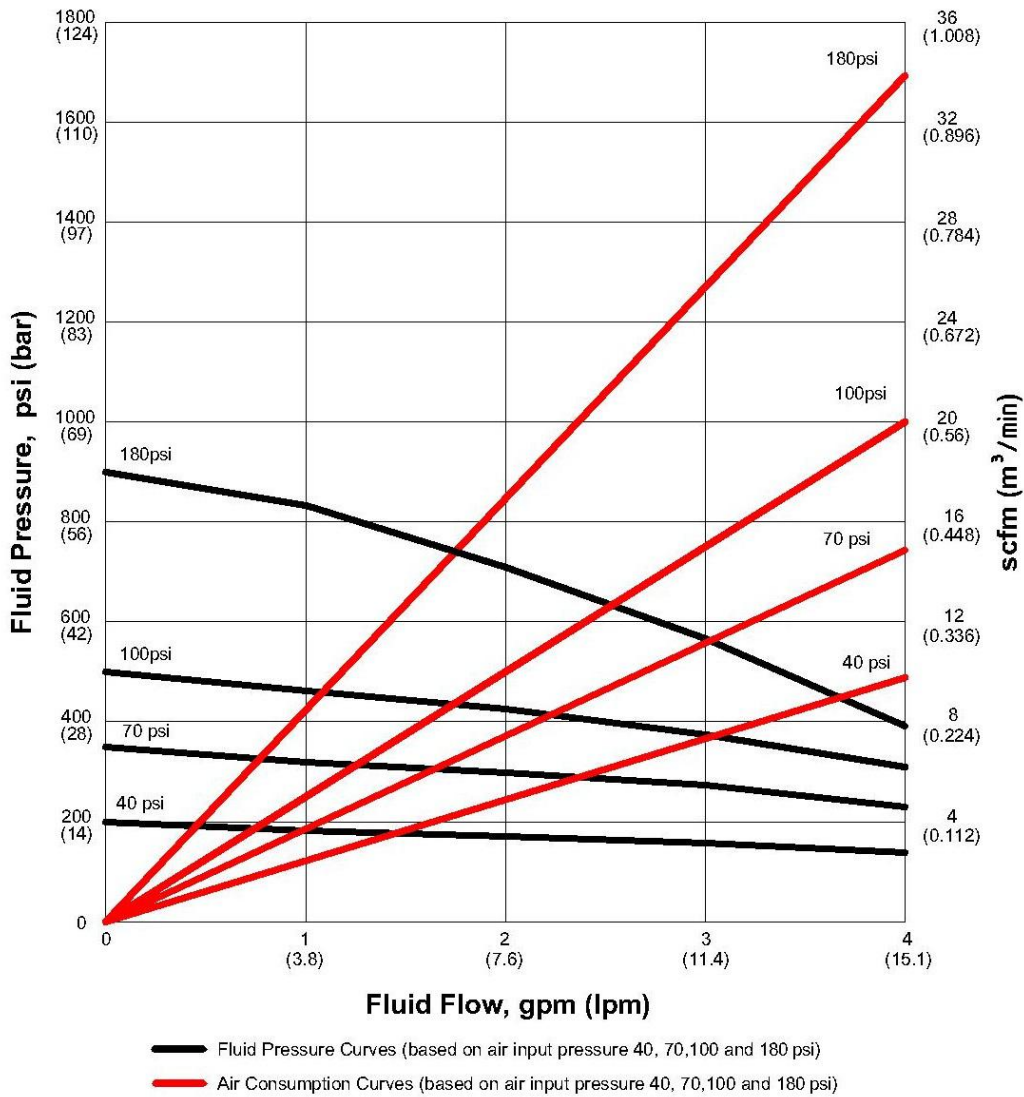

**Dimensions**

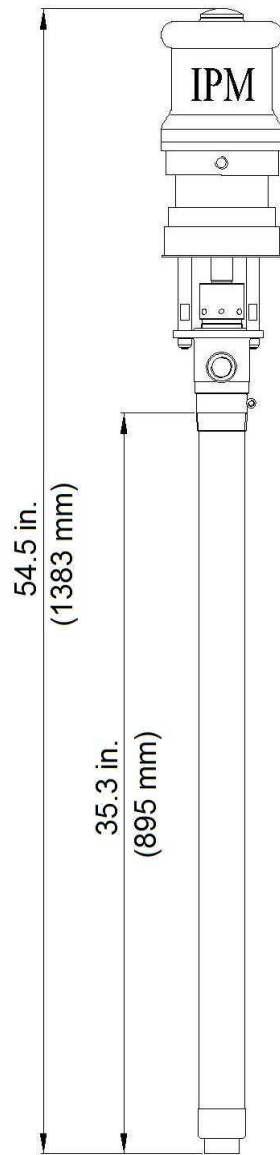

830802

## **9.0 WARRANTY AND DISCLAIMER**

### **Warranty**

International Pump Manufacturing, Inc. (hereafter designated IPM) warrants the equipment it manufactures to be free of defects in materials and workmanship for a period of one (1) year from the date of sale from IPM to an authorized IPM distributor or to the original end user and/or purchaser. IPM will, at its discretion, repair or replace any part of the equipment proven to be defective. This warranty applies only when the equipment is used for the intended purpose and has been installed, operated and maintained in accordance with written operating procedures.

A condition of the warranty is the prepaid return of the equipment to an authorized distributor of IPM who shall provide verification of the warranty claim. IPM will repair or replace free of charge any parts found and verified to be defective or damaged upon receipt of equipment. Shipping will be prepaid for the repaired or replaced parts under warranty. Should inspection of the equipment reveal no defects in material or workmanship repairs will be made at the standard IPM rate, which will include parts, inspection, labor, packaging and shipping.

The warranty does not apply nor shall IPM be liable for damage, operational wear, malfunction of equipment caused by improper installation, misuse, chemical abrasion or corrosion, operator negligence, accident, tampering or altering of equipment, lack of improper maintenance and/or by substitution of non-IPM parts. Additionally, IPM shall not be liable for nor does the warranty apply to operational wear, damage or malfunction caused by incompatibility of accessories, components, structures, equipment or materials not supplied by IPM. The warranty does not apply to nor will IPM be responsible for the improper operation, maintenance, design, manufacture, installation of components, accessories, equipment or structures not supplied by IPM.

The warranty is void unless the Warranty Registration Card is properly completed and returned to IPM within ONE (1) month of the date of the sale.

### **Limitations and Disclaimers**

This warranty is the sole and exclusive remedy for the purchaser. No other warranties, expressed or implied, warranties for fitness of purpose or merchantability, or non-contractual liabilities are made by IPM, including product liability, whether on negligence or a strict liability basis. Liability for directly special or non-contractual damages or loss is expressly excluded and denied. IPM's liability shall in no case exceed the amount of the purchase price.

IPM does not warrant and disclaims implied warranties of merchantability and fitness for a particular purpose, components, accessories, equipment, materials sold but not manufactured by IPM. These parts (valves, hoses, fittings, etc.) are subject to the provisions within the warranty of the actual manufacturer of these items. IPM will provide reasonable assistance with warranty claims on these items.



**3107 142nd Avenue East Suite 106  
Sumner, WA 98390  
U.S.A.**

**TEL: (253) 863 2222 FAX: (253) 863 2223  
Website: [www.ipmpumps.com](http://www.ipmpumps.com)**

**Updated December 2022**